

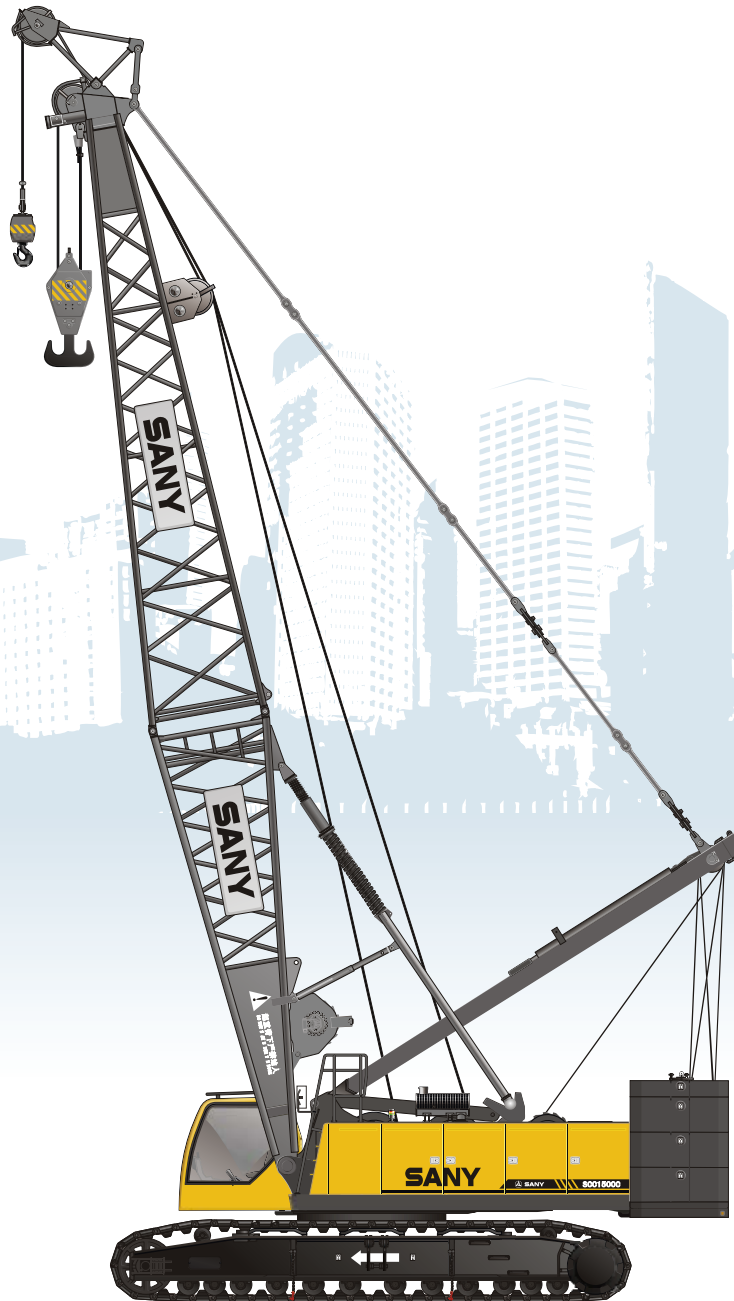

SANY

Quality Changes the World



SANY CRAWLER CRANE SCC 1500C

CRAWLER CRANE

CONTENT

P3

SCC1500C Crawler Crane

- Outline Dimensions
- Performance Data
- Transportation Dimensions
- Assembly Diagram

P11

Specifications

- Upperworks
- Undercarriage
- Operation Device
- Safety Device

P20

Combination of operating conditions

- Operating Condition Combination
 - H Operating Condition
 - FJ Operating Condition

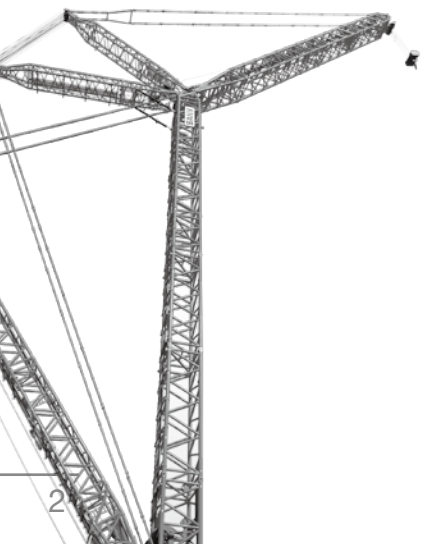



SCC1500C

- 04 Outline Dimensions
- 05 Performance Data
- 06 Transportation Dimensions
- 10 Assembly Diagram

OUTLINE DIMENSIONS

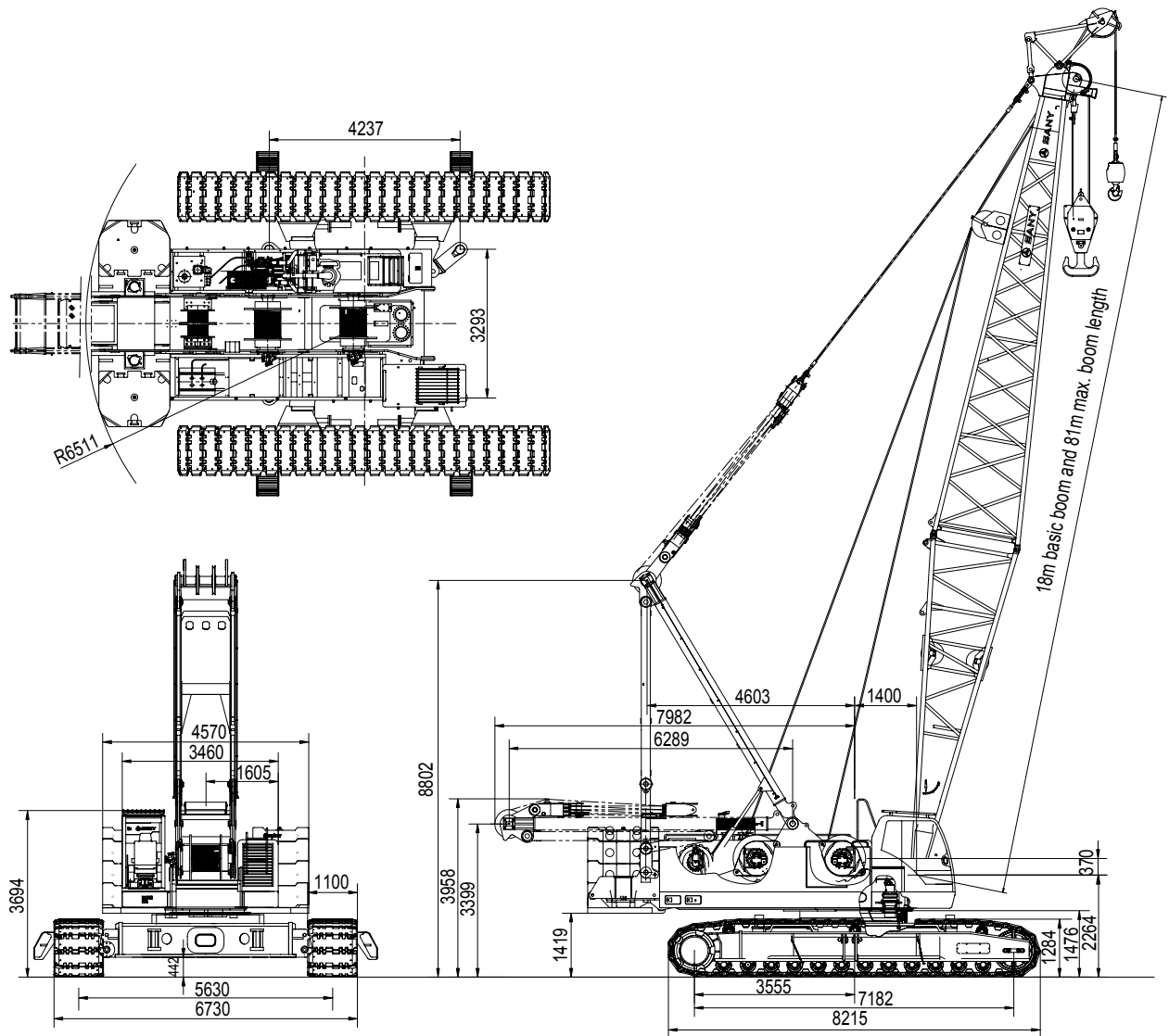

Basic Dimensions of the Whole Machine of SCC1500C crawler crane

PERFORMANCE DATA

Main technical parameters of 1500C crawler crane			
Performance index		Unit	Data
Boom operating condition	Maximum lifting capacity	t	150
	Boom length	m	18~81
	Boom luffing angle	°	30~ 80
Fixed jib operating condition	Max. length boom + Max. length jib	m	(69+31) / (75+13)
	Angle between boom and fixed jib	°	15, 30
Speed parameters	Rope speed of main and auxiliary winches	m/min	0~125
	Rope speed of Luffing winch(outermost)	m/min	(0~24) ×2
	Swing speed	rpm	0~2
	Traveling speed	km/h	0~1.2/0~0.6(two speeds)
	Gradeability	%	30
Engine	Output power/rated rotational speed	kW/rpm	242 /2100
Transportation parameter	Maximum transport weight of single unit	t	50.2
	Transportation dimension (length*width*height)	mm	10230×3470×3500
Other parameters	Average ground pressure	MPa	0.093

TRANSPORT DIMENSIONS

Basic machine (without boom base)	×1
Length	10.23m
Width	3.47m
Height	3.50m
Weight	50.2t
Basic machine (with boom base)	×1
Length	16.99m
Width	3.47m
Height	3.50m
Weight	53.6t
Track frame	×2
Length	8.25m
Width	1.54m
Height	1.29m
Weight	21.7t
Boom tip	×1
Length	10.91m
Width	2.21m
Height	2.35m
Weight	2.28t
Boom base	×1
Length	7.76m
Width	2.21m
Height	2.13m
Weight	4.2t
3m boom insert	×1
Length	3.14m
Width	2.21m
Height	2.01m
Weight	0.66t
6m boom insert	×3
Length	6.14m
Width	2.21m
Height	2.01m
Weight	1.11t

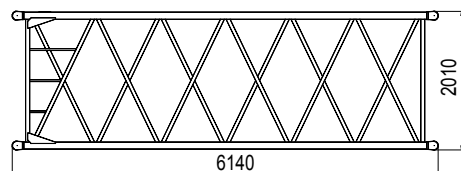
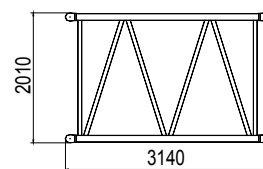
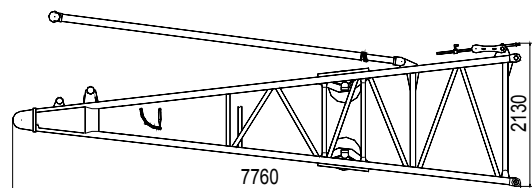
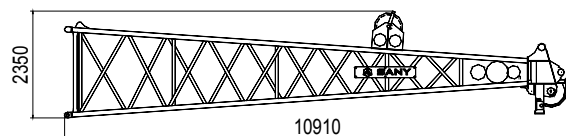
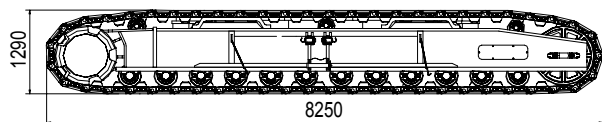
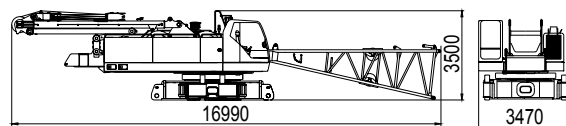
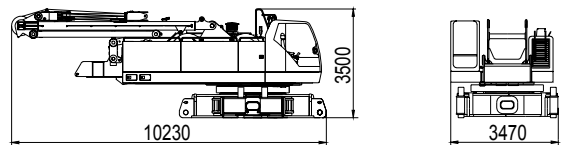

TRANSPORT DIMENSIONS

9m boom insert	×2
Length	9.14m
Width	2.21m
Height	2.16m
Weight	1.6t
12m boom insert	×2
Length	12.14m
Width	2.21m
Height	2.01m
Weight	1.9t
Jib tip	×1
Length	5.41m
Width	1.01m
Height	1.17m
Weight	0.27t
Jib base	×1
Length	5.11m
Width	1.03m
Height	0.83m
Weight	0.27t
3m jib insert	×1
Length	3.08m
Width	1.01m
Height	0.83m
Weight	0.14t
6m jib insert	×3
Length	6.08m
Width	1.01m
Height	0.83m
Weight	0.25t
Jib Extension	×1
Length	2.15m
Width	1.04m
Height	1.12m
Weight	0.36t

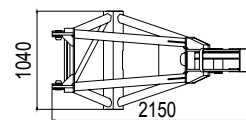
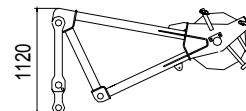
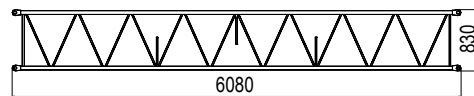
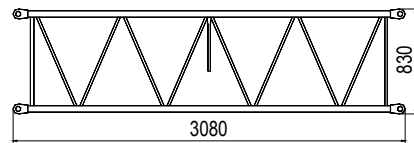
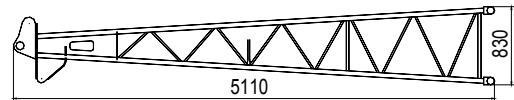
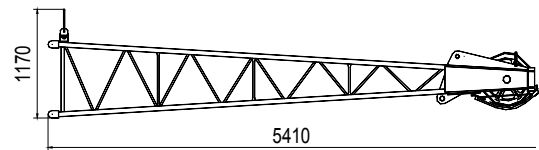
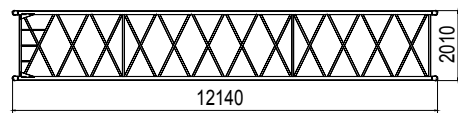
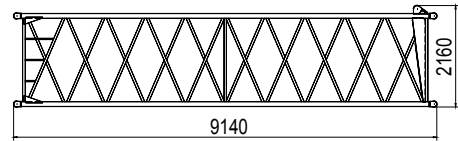

TRANSPORT DIMENSIONS

Fixed jib strut	×1
Length	5.44m
Width	1.14m
Height	0.21m
Weight	0.4t
Counterweight tray	×1
Length	4.68m
Width	1.90m
Height	0.47m
Weight	13t
Counterweight block	×8
Length	1.97m
Width	1.90m
Height	0.69m
Weight	5.5t
Counterweight block	×2
Length	1.97m
Width	1.90m
Height	0.35m
Weight	3.0t
150t hook block	×1
Length	0.89m
Width	1.03m
Height	2.44m
Weight	2.8t
100t hook block	×1
Length	0.93m
Width	0.84m
Height	2.36m
Weight	1.99t

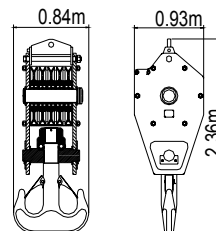
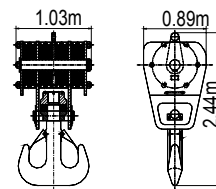
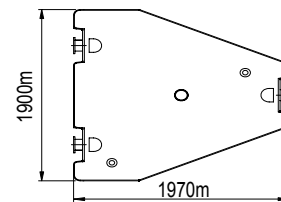
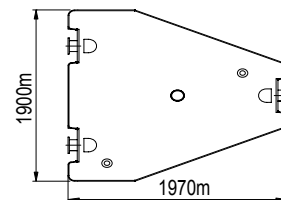
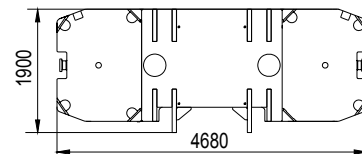
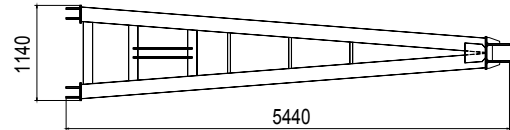

TRANSPORT DIMENSIONS

50t hook block	×1
Length	0.89m
Width	0.47m
Height	1.95m
Weight	1.06t
25t hook block	×1
Length	0.90m
Width	0.37m
Height	1.87m
Weight	0.79t
13.5t hook block	×1
Length	0.50m
Width	0.50m
Height	0.95m
Weight	0.53t

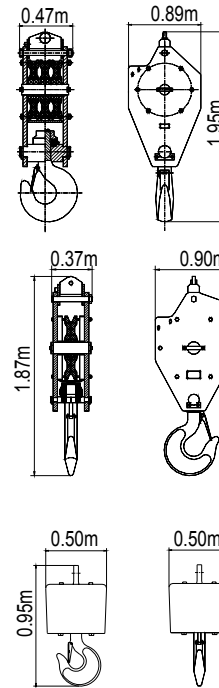

Notes: 1.Transportation dimensions of main parts are not drawn to proportion, The dimensions in the sketch are design value exculding packages.

2.The weight is design value and the weight tolerance caused by manufacturing error is $\pm 2\%$.

ASSEMBLY DIAGRAM

The machine has self-assembly function of track traveling device. The track traveling device should be first mounted before counterweight when assembly. However, counterweight

dismantlement should be done before track traveling device for disassembly. Please refer to following figure for detailed operation process.

1) Self-assembly

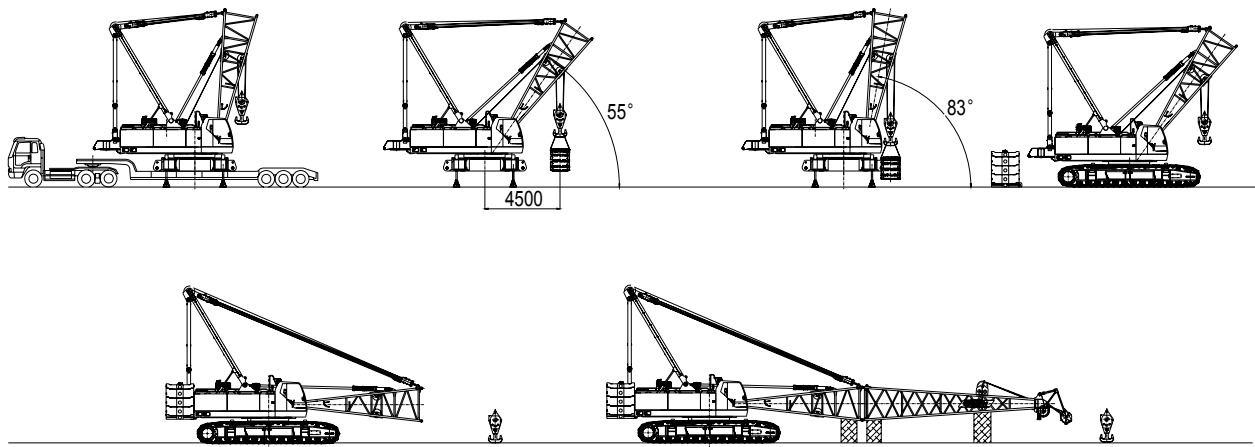

Self-assembly sketch (reverse steps for disassembly)

2) Installation of fixed jib operation support

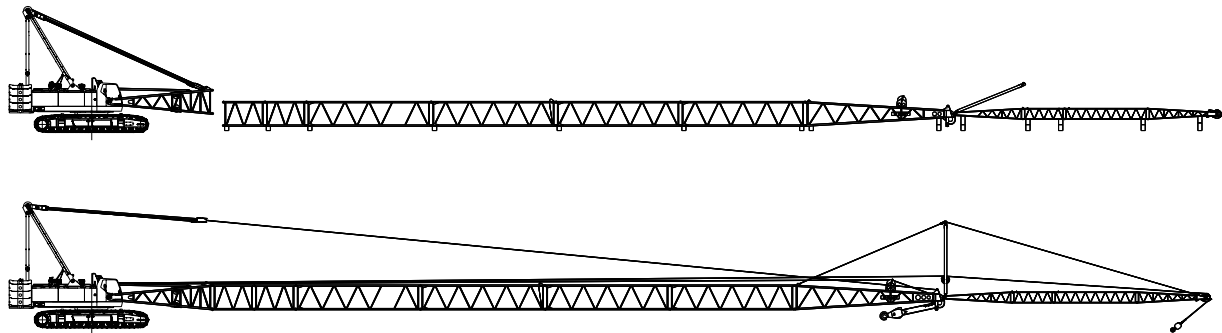

Installation sketch of fixed jib



SCC1500C

12	Uperworks
15	Lowerworks
16	Operation Device
17	Safety device

UPERWORKS

1) Engine

- Imported Cummins QSL9, inline 6-cylinders.
- Rated power / speed: 242KW/2100rpm.
- Maximum torque: 1424N·m/1500rpm.
- Emission standards: European tier 3.
- Air filter: double filtration system composed of air pre-filter and air filter.
- Fuel tank: capacity of 400L with oil leveler and electronic display for fuel oil volume.
- Emission standard: Tier III.

2) Electrical control system

- Controller, combination instrument, engine, load moment indicator, remote control terminal apply CAN bus techniques for data communication.
- Combined instrument can display parameters such as engine rotating speed, fuel quantity, machine oil pressure, servo pressure, wind speed, the engine operating working hours and primary winch lock, primary-to-amplitude winch lock, turn lock and other working conditions.
- Reliability: International or industrial famous brands shall be used for main electric devices. They mainly include load moment limiter, controller, displayer, sensor, monitoring switch, control switch, electric wires and cables.
- Comfort: Electric parameters of various points can be shown by instruments, including the operation parameters such as engine speed, fuel oil volume, machine oil pressure, servo pressure, wind speed and operation time etc. and the working state such as main winch locking, boom locking and slewing locking. Installation and operation modes can be separated to lock the main hydraulic action and to lighten drivers' operation strength.
- Advancement: It adopts the overall CAN bus system, load power limit control, redundancy communication check and optional global positioning and remote monitoring program.

3) Hydraulic System

Configuration of hydraulic system: adopt the world-renowned brands of hydraulic systems, including the main pump, main valve, control handle and motor reducer. It is efficient, energy saving, stable and reliable.

It has excellent micro-rotation and performance improvement, load sensing; limit load regulation makes the operation more stable.

Adopt controlled hydraulic oil cooling system independently.

4) Main and auxiliary hoisting mechanisms

- Main or auxiliary winch has advantages such as individual drive, compact structure, easy installation, low abrasion and maintenance-free embedded wet brake so as to guarantee winch safety.
- Variable hydraulic motor shall realize the maximum winch speed by automatic displacement adjustment according to load.
- High-quality stainless steel wire rope shall be adopted with features of high hoisting safety and service life.
- Bag type rope head shall be adopted for convenient detachment & installation of steel wire rope. Pawl and ratchet locking device shall be fitted for safer hoisting.

Main lifting device

Drum diameter	496mm
Rated tension of single wire speed of the outermost layer	0~125m/min
Diameter of steel wire rope	26mm
Length of steel wire rope of main winch	350m
Rated single line pull	13.1t

Auxiliary lifting device

Drum diameter	496mm
Rated tension of single wire speed of the outermost layer	0~125m/min
Diameter of steel wire rope	26mm
Length of auxiliary winch steel wire rope	300m
Rated single line pull	13.1t

5) Swing mechanism

- It is driven by swing motor and buffered hydraulically to provide 360° rotation.
- Brake: Normally closed, embedded, wet type, and spring disc-type brake, with spring force braking and oil pressure releasing.
- Swing lock: swing lock device is employed for non-impact on the slewing upper part during the load traveling and transportation process.
- Swing ring: 3-rows roller column type slewing ring.
- Swing speed: 0-2.0r/min.

6) Luffing mechanism

It is fitted with double luffing winch drums, with ratchet wheel & pawl locking device for middle spacer plate of double drum so as to guarantee parking safety of suspension boom under non-operation status.

Luffing mechanism

Winch diameter	460mm
Rated tension of single wire speed of the outermost layer	(0~24)×2 m/min
Diameter of steel wire rope	20mm
Length of steel wire rope of luffing winch	320m
Rated single line pull	9.73t

7) Counterweight

Name	Quantity	Weight of single part	Total weight
Counterweight block	6	5.5	33
Counterweight block	2	3	6
Counterweight tray	1	13	13
Total nominal counterweight (kg)		52	
Additional counterweight	2	5.5	11
Total weight of all counterweight (kg)		63	

8) Cab

- Newly designed sliding-door cab, large area windows; with near and far beam headlamp, rear-view mirrors and more open vision.
- Installed with heating and cool air conditioning, MP3 player; seats, control handle; control button layout designed according to ergonomic; thus operation is more comfortable.

9) Control operation

- All actions of crawler traveling device are realized by traveling pedal (or control lever). The left track can be driven by the left traveling pedal (control lever) and right track by the right traveling pedal (control lever); the engine rotational speed can be controlled by the foot or hand throttle. Startup switch of engine is located on the right armrest box. Luffing or main winch control lever is located on the right armrest box and auxiliary winch and slewing control lever on the left box. Slewing locking button is located at the left side of left armrest box. The auxiliary operation box is at the left front of seat, with all switches on its control panel operated manually to realize corresponding functions.
- Traveling pedal (control lever) has automatic positive function. That is, positive control direction is that of operator.

LOWERWORKS

1) Crawler traveling device

The track frame on both sides adopts separate walk-driven devices. Walking motor can achieve lineal walk and turn of the whole machine through motor reducer and driving wheel.

2) Traveling brake

Built-in, wet, spring-loaded normal-engaged disk brake applies braking through spring force and release braking through oil pressure.

3) Track shoes

High-strength alloy steel track link with longer life.

4) Chassis

Hydraulic cylinder is to drive power pin for connection to crawler system to facilitate installation and detachment. High-strength welded frame structure.

5) Traveling speed

- Low-speed:0.6 km/h
- High-speed:1.2 km/h

OPERATION DEVICE

1) Boom

- Truss structures; the main chord adopts high strength structure steel; each section is connected with pins.
- Basic boom 18m: 7.5m tip +10.5m base.
- Boom insert: 3m'× 1,6m× 3,9m× 2,12m× 2.
- Boom Length: 18m~ 81m.

2) Fixed jib

- Truss structures; the main chord adopts high strength structure steel; each section is connected with pins.
- Fixed jib can be mounted on the boom between 27m and 75m.
- Basic boom: 5m tip +5m base.
- Boom insert: 3m×1, 6m×3.
- Jib Length: 13m~ 31m' .
- The longest boom + jib: 69m boom +31m jib;75m boom + 13m jib.

3) Hook Block

- | | | |
|---------------------------|-------|------------|
| ■ Standard configuration: | 150t | hook block |
| | 50t | hook block |
| | 13.5t | hook block |
| ■ Optional configuration: | 25t | hook block |
| | 100t | hook block |

Notes: The operation devices above are safe configuration; order contract shall prevail for specific configuration.

SAFETY DEVICE

1) Load Moment Indicator (LMI)

- Standard configuration, optional manufacturer.
- A completely separate and secure computer-controlled operating system; LMI can automatically detect the load of cranes and the angle of lifting arm and show its rated load and actual load, working radius and boom angle.
- Functions: can real-time display rated load, actual load, working radius and boom angle, height and other data at current status of the crane. Automatically detect luffing angle transfinite and load transfinite and other dynamic data, and give real-time alarm and limit movement.
- It mainly consists of display, basic machine box, angle sensor and force sensor.
- Components: display, machine, monitor, angle sensors, force sensors etc.

2) Anti-roll out equipments of main and auxillary hoists

It is composed of movement trigger device and proximity switches installed in roll to prevent wire rope from being over-decentralized. When the wire rope is over-decentralized near the last three hoops, limit switch will work, the system will alarm through buzzer, alarm information will be displayed in instrument cluster and automatically stop the decentralization movement of hoist.

3) Anti-pulley equipments of main and auxillary winch

Composed of limit switch, hammer etc. on jib to prevent excessive promotion of hook block. When the lifting hook raises to a certain height, limit switch will work, the buzzer on the control panel will alarm, meanwhile the failure indicator blinks and automatically stop the lifting operation of hook block.

4) Switch between installation/operation mode

In installation mode, anti roll device, lifting boom inhibiting device, load moment indicator do not work to facilitate crane installation. In operation mode, all the safety limit devices are working.

5) Boom inhibiting device

When the elevation angle of lifting arm is greater than the buzzer will alarm, and boom elevation control will be closed. This protection is controlled by load moment limiter and position switch.

6) Boom back-stop device

- The high pressure of back-stopping cylinder should be overcome when the boom tilts backwards. Hydraulic system can compensate the high-pressure oil when the boom stretches out forwards, to tighten the pendant rod of boom, thus preventing the vibration and back-stop during operation process.
- There is a pair of back-stop oil cylinders on the rear mast of luffing jib and there is also a pair of oil cylinders on the front mast of luffing jib to prevent the mast backwards and to tighten the luffing wire rope of luffing jib.
- Mechanical Back-stop device shall be set for jib angle of 8° between jib and extension line of boom to avoid tipback.

7) Winch mechanism

Spring-loaded disk-type brake which is normally closed shall be employed for all winch brakes, which is characterized with the large brake force, maintenance-free, safe and reliable usage and long service life.

8) Monitoring system

Operator in cab can monitor the real-time status of luffing drum, hoisting winch drum and vehicle tail by video camera with high resolution.

9) Self-diagnosis system

It can generate fault and alarm information automatically to review the operation & electrification status of electrical lines so as to eliminate the electrical fault quickly.

10) Boom alarm light

It is installed on the top of boom to overhead prompt, without stopping the operation of boom at night.

11) Wind velocity indicator

It is installed on the top of boom for the real-time monitoring of wind speed and then transfers the data to the cab for displaying them on the monitor.

12) Level gauge

Electronic leveling gauge can display tilt angle of upper works on monitor.

13) Boom angle sign plate

Pendulum angle indicator device is located in boom base next to the cab for operator convenience.

14) Hook latch

Each kind of lifting hook is fitted with baffle to avoid the steel wire falling-off.

15) Operation Alarm

Press the horn to give an alarm before any operation of crane to prompt to other persons pay attention to safety.

16) Traveling or slewing prompt

Operation alarm lamp flickers and slewing buzzer rings during traveling or slewing traveling.

17) Permissible functional handle

All other function control handles will fail if the permissible functional handle can not be at the proper position, to avoid mis-operation caused by body collision when getting-on/off.

18) Seat-leaving Protection Device

While the operator is not on the seat, all the control could not work.

19) Automatic reversing driving

No matter the relative position between superstructure and undercarriage, the entire machine moves forwards if pushing the driving pedal forwards and backwards if pushing backwards.

20) Engine power limit load regulation and stall protection

Real-time monitoring shall be done for output power of engine. Power load can be adjusted to avoid engine suppression and stalling.

21) Monitoring Display

High-resolution true color displayer and electric human-machine dialog displayer terminal can display operation parameters of engine system, operation status and parameters of hydraulic system, parameter status of various detection points and output points of electric system as well as real-time parameters under various ambient conditions.

SCC1500C

The background of the page is a photograph of a construction site. A large, lattice-structured tower crane is the central focus, extending from the bottom right towards the top center. To the left, a concrete structure is under construction, featuring a horizontal beam and a vertical column. The sky is a clear, bright blue. The overall scene is industrial and captures a moment of active construction.

Operating Condition Combination 21

H Operating Condition of Boom 22

FJ Operating Condition of Fixed Jib 23

OPERATING CONDITION COMBINATION

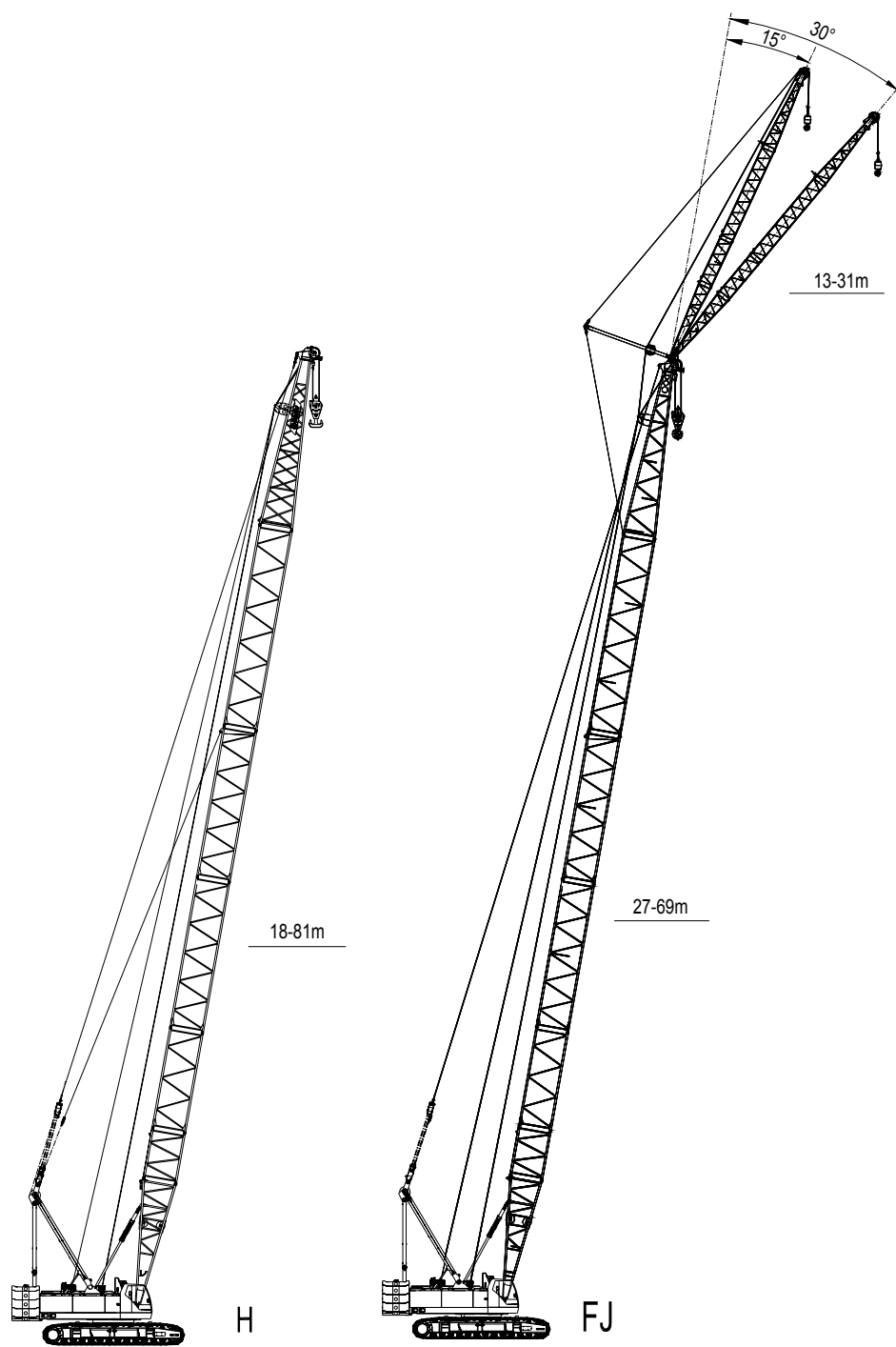

H operating condition

FJ operating condition

H OPERATION CONDITION

Boom length	Insert			
	3 m	6 m	9 m	12 m
18	-	-	-	-
21	1	-	-	-
24	-	1	-	-
27	1	1	-	-
30	1	-	1	-
	-	2	-	-
33	1	2	-	-
	-	1	1	-
36	1	1	1	-
	1	1	-	1
39	1	-	2	-
	-	2	1	-
42	1	2	1	-
	1	-	1	1
45	-	1	2	-
	1	1	1	1
48	1	1	1	1
	1	1	-	2
51	1	-	2	1
	-	2	1	1
54	1	2	1	1
	1	-	1	2
57	-	2	-	2
	1	1	2	1
60	1	1	1	2
	1	-	2	2
63	1	2	2	1
	1	2	1	2
66	1	1	2	2
	1	3	2	1
72	-	2	2	2
	1	3	1	2
75	1	2	2	2
78	-	3	2	2
81	1	3	2	2

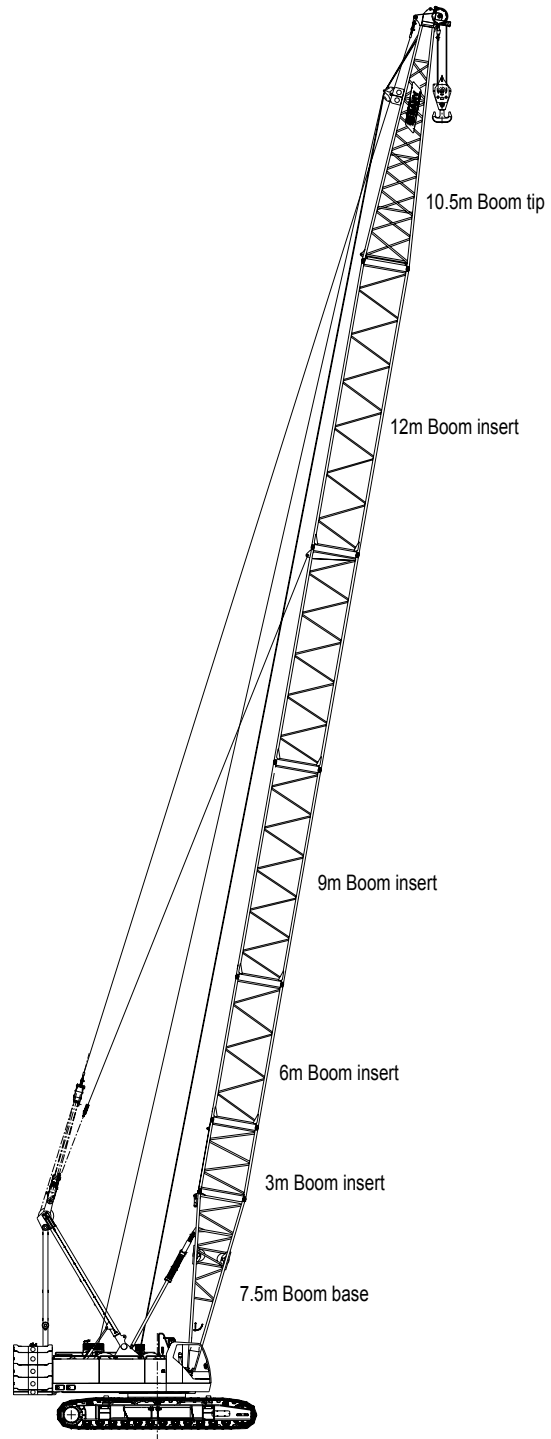

H OPERATION CONDITION RANGE DIAGRAM

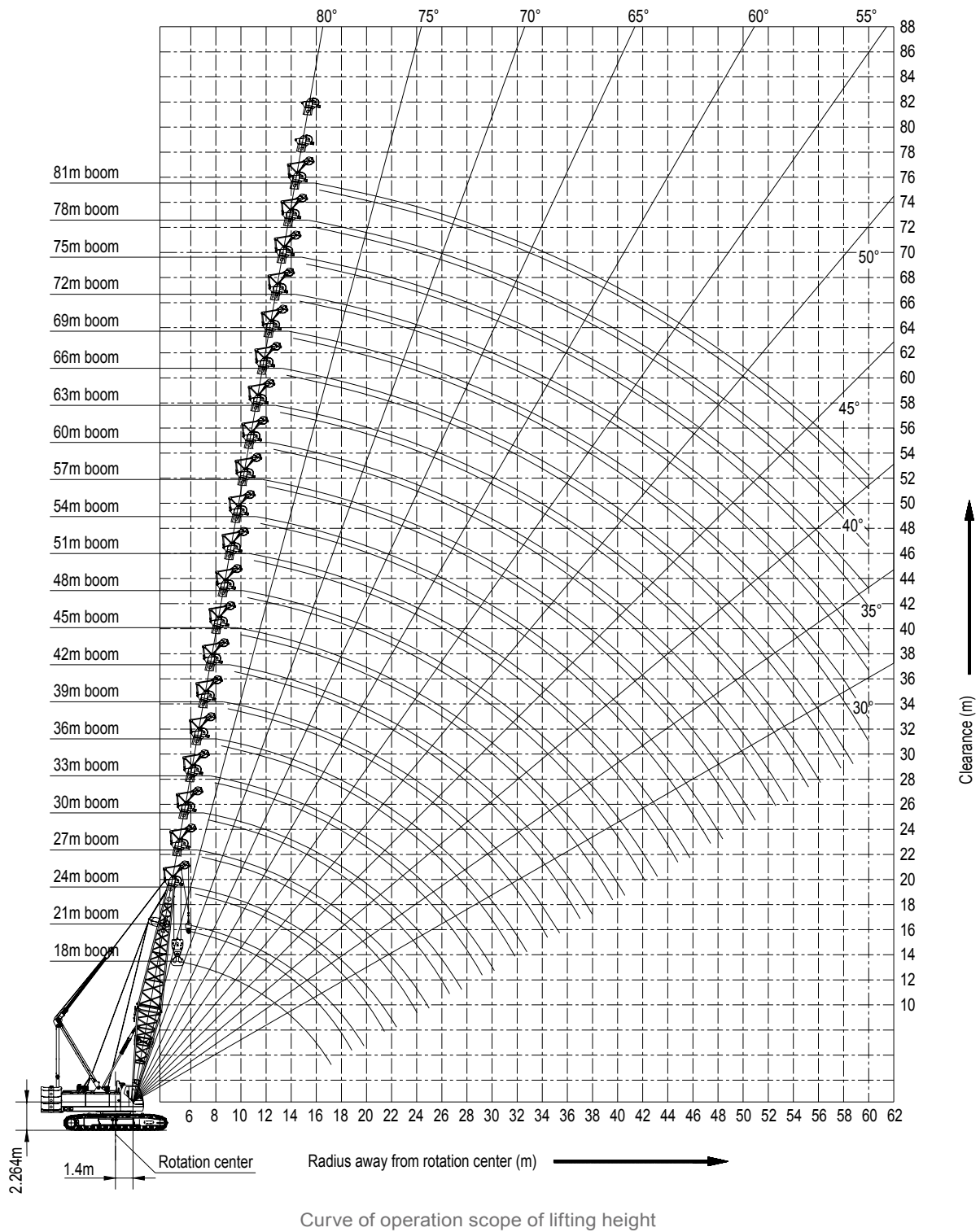

BOOM LOAD CHART (H OPERATING CONDITION)

Note:

1. Filling part of 25% orange level in bold frame in the table is determined by strength. Italic value filled by 40% orange level refers to the operating conditions with standard and additional counterweights.
2. Rated load in the table is the maximum permissible value under the condition that the non-traveling heavy load is slowly and stably lifted from the solid and flat ground.
3. Rated load shown in the table is calculated based on the 75% of tilting load under wind speed of less than 9.8m/s. Value unit expressed by load is “t”. Actual hoisting weight is value by deducting mass of main or auxiliary lifting hook from rated hoisting weight in the table. Weight of lifting hook is shown as follows:
 - 150t hook block -2.8t
 - 100t hook block --1.99t
 - 50t hook block --1.06t
 - 25t hook block -0.79t
 - 13.5t hook block -0.53t
4. All values in load chart are available for 360° rotation.
5. Length of installable boom is from 18m to 81m.
6. It is selected operating condition with additional counterweight (52t+11t) and it does not belong to standard operating conditions. Length of boom with additional counterweight allowed is from 45m to 81m.

BOOM LOAD CHART (H OPERATING CONDITION)

H operation condition load chart 1/3

Unit: (t)

Boom length (m) Radius (m)	18	21	24	27	30	33	36	39	42	45	
5	155/4.94	135.3/5.46									
6	144.0	129.8	120.3/5.95	106.1/6.5							
7	124.5	118.2	107.8	101.8	95.7	85.8/7.54					
8	99.7	99.6	99.4	99.2	90.1	83.9	77.9/8.07	70.8/8.58			
9	83.0	82.8	82.7	82.4	82.3	82.0	74.7	68.7	64.5/9.1	58.7/9.63	58.7/9.63
10	70.9	70.8	70.6	70.4	70.2	70.0	69.8	64.8	62.2	57.9	57.9
11	61.9	61.7	61.5	61.3	61.1	60.9	60.7	61.1	57.8	56.7	56.7
12	54.8	54.6	54.5	54.2	54.1	53.8	53.6	53.4	53.3	53.1	55.5
13	49.1	48.9	48.8	48.5	48.4	48.1	47.9	47.8	47.6	47.4	54.3
14	44.5	44.3	44.1	43.8	43.7	43.4	43.3	43.1	42.9	42.7	49.0
15	40.6	40.4	40.2	40.0	39.8	39.5	39.4	39.2	39.0	38.8	44.6
16	37.3	37.1	36.9	36.7	36.5	36.2	36.1	35.9	35.7	35.5	40.8
17	34/17.19	34.3	34.1	33.8	33.7	33.4	33.2	33.0	32.9	32.7	37.6
18		31.8	31.7	31.4	31.2	31.0	30.8	30.6	30.4	30.2	34.8
19		29.7	29.5	29.2	29.1	28.8	28.6	28.4	28.3	28.1	32.4
20		28.1/19.8	27.6	27.3	27.2	26.9	26.7	26.5	26.4	26.2	30.2
21			25.9	25.6	25.5	25.2	25.0	24.8	24.7	24.5	28.3
22			23.9/22.4	24.1	24.0	23.7	23.5	23.3	23.2	23.0	26.6
23				22.8	22.6	22.3	22.2	22.0	21.8	21.6	25.1
24				21.5	21.4	21.1	20.9	20.7	20.6	20.4	23.7
26				20.4/25	19.2	18.9	18.8	18.6	18.4	18.2	21.2
28					17.8/27.6	17.1	17.0	16.8	16.6	16.4	19.2
30						15.5/30.2	15.4	15.2	15.1	14.9	17.4
32							14.1	13.9	13.7	13.5	15.9
34							13.6/32.8	12.7	12.6	12.4	14.6
36								12/35.38	11.6	11.3	13.4
38									10.7/37.95	10.4	12.4
40										9.4/40.58	11.3/40.58
Counterweight	52	52	52	52	52	52	52	52	52	52	52+11
Multiply	14	12	10	9	8	7	6	6	5	5	5

BOOM LOAD CHART (H OPERATING CONDITION)

H operation condition load chart 2/3

Unit: (t)

Boom length (m)	48		51		54		57		60		63	
Radius (m)												
10	54/10.1	54/10.1	49.3/10.6	49.3/10.6								
11	52.5	52.5	48.3	48.3	45.5/11.2	45.5/11.2	41.8/11.7	41.8/11.7				
12	50.9	50.9	47.2	47.2	44.2	44.2	41.4	41.4	39.2/12.2	39.2/12.2		
13	47.2	49.5	45.5	45.5	43.0	43.0	40.1	40.1	37.9	37.9	35/12.75	35/12.75
14	42.5	48.1	42.3	43.8	42.1	42.5	38.7	38.7	36.7	36.7	33.6	33.6
15	38.6	44.3	38.4	42.1	38.1	40.6	38.0	37.9	35.0	35.0	32.2	32.2
16	35.3	40.6	35.1	40.4	34.8	38.7	34.7	36.6	33.3	33.3	30.8	30.8
17	32.5	37.4	32.3	37.2	32.0	36.9	31.8	35.2	31.6	32.2	29.4	29.4
18	30.0	34.6	29.8	34.4	29.5	34.1	29.3	33.9	29.2	31.2	28.0	28.0
19	27.8	32.1	27.6	31.9	27.4	31.7	27.2	31.5	27.0	30.1	26.8	27.5
20	25.9	30.0	25.7	29.8	25.5	29.5	25.3	29.3	25.1	29.1	24.9	27.0
21	24.2	28.1	24.0	27.9	23.8	27.6	23.6	27.4	23.4	27.2	23.2	26.1
22	22.7	26.3	22.5	26.1	22.2	25.9	22.1	25.7	21.9	25.5	21.6	25.3
23	21.3	24.8	21.1	24.6	20.9	24.3	20.7	24.1	20.5	23.9	20.3	23.7
24	20.1	23.4	19.9	23.2	19.6	22.9	19.5	22.7	19.3	22.5	19.0	22.3
26	18.0	21.0	17.8	20.8	17.5	20.5	17.3	20.3	17.1	20.1	16.9	19.9
28	16.1	18.9	15.9	18.7	15.7	18.4	15.5	18.3	15.3	18.0	15.1	17.8
30	14.6	17.2	14.4	17.0	14.1	16.7	13.9	16.5	13.7	16.3	13.5	16.1
32	13.3	15.7	13.1	15.5	12.8	15.2	12.6	15.0	12.4	14.8	12.2	14.6
34	12.1	14.3	11.9	14.1	11.6	13.9	11.4	13.7	11.2	13.5	11.0	13.3
36	11.1	13.2	10.9	13.0	10.6	12.7	10.4	12.5	10.2	12.3	10.0	12.1
38	10.2	12.2	10.0	12.0	9.7	11.7	9.5	11.5	9.3	11.3	9.1	11.1
40	9.4	11.3	9.2	11.0	8.9	10.8	8.7	10.6	8.5	10.4	8.3	10.2
42	8.7	10.4	8.5	10.2	8.2	9.9	8.0	9.8	7.8	9.6	7.6	9.3
44	8.3/43.2	10.0/43.2	7.3/45.75	8.9/45.75	7.5	9.2	7.3	9.0	7.1	8.8	6.8	8.6
46					6.9	8.5	6.7	8.3	6.5	8.1	6.2	7.9
48					6.2/48.38	7.8/48.38	6.1	7.7	5.9	7.5	5.6	7.3
50							5.3/50.97	6.9/50.97	5.3	6.9	5.1	6.7
52									4.8	6.4	4.6	6.1
54									4.5/53.57	6.0/53.57	4.1	5.6
56											3.7/56.16	5.1/56.16
Counterweight	52	52+11	52	52+11	52	52+11	52	52+11	52	52+11	52	52+11
Multiply	5	5	4	4	4	4	4	4	4	4	3	3

BOOM LOAD CHART (H OPERATING CONDITION)

H operation condition load chart 3/3

Unit: (t)

Boom length (m) Radius (m)	66	69	72	75	78	81						
13	31.5/13.2	31.5/13.2										
14	30.9	30.9	28.3/13.8	28.3/13.8	25.5/14.3	25.5/14.3						
15	29.8	29.8	27.3	27.3	24.9	24.9	22.7/14.8	22.7/14.8	22/15.3	22/15.3		
16	28.6	28.6	26.5	26.5	24.3	24.3	22.1	22.1	21.4	21.4	20.6	20.6
17	27.5	27.5	25.6	25.6	23.6	23.6	21.6	21.6	20.9	20.9	20.2	20.2
18	26.4	26.4	24.6	24.6	22.9	22.9	21.1	21.1	20.4	20.4	19.7	19.7
19	25.2	25.2	23.7	23.7	22.1	22.1	20.6	20.6	19.9	19.9	19.2	19.2
20	24.0	24.0	22.7	22.7	21.4	21.4	20.1	20.1	19.4	19.4	18.7	18.7
21	22.9	23.5	21.8	21.8	20.7	20.7	19.6	19.6	18.9	18.9	18.2	18.2
22	21.4	23.0	20.8	20.8	19.9	19.9	19.0	19.0	18.4	18.4	17.7	17.7
23	20.0	22.5	19.8	20.3	19.2	19.2	18.5	18.5	17.8	17.8	17.2	17.2
24	18.8	22.1	18.6	19.8	18.3	18.5	17.9	17.9	17.3	17.3	16.7	16.7
26	16.6	19.6	16.4	18.6	16.2	17.8	16.0	17.0	15.7	16.5	15.5	16.0
28	14.8	17.6	14.6	17.4	14.4	17.1	14.2	16.1	13.9	15.6	13.7	15.4
30	13.3	15.8	13.1	15.6	12.8	15.4	12.6	15.2	12.4	14.9	12.2	14.7
32	11.9	14.3	11.7	14.1	11.5	13.9	11.3	13.7	11.0	13.4	10.8	13.2
34	10.8	13.0	10.6	12.8	10.3	12.6	10.1	12.3	9.9	12.1	9.7	11.9
36	9.8	11.9	9.5	11.6	9.3	11.4	9.1	11.2	8.8	10.9	8.6	10.7
38	8.9	10.8	8.6	10.6	8.4	10.4	8.1	10.1	7.8	9.9	7.6	9.7
40	8.0	9.9	7.8	9.7	7.5	9.4	7.2	9.2	6.9	9.0	6.7	8.7
42	7.3	9.1	7.0	8.9	6.7	8.6	6.4	8.4	6.2	8.1	5.9	7.8
44	6.6	8.4	6.3	8.1	6.0	7.8	5.7	7.6	5.4	7.3	5.2	7.0
46	5.9	7.7	5.6	7.4	5.4	7.1	5.1	6.8	4.8	6.5	4.5	6.3
48	5.3	7.0	5.1	6.7	4.8	6.4	4.5	6.2	4.2	5.9	4.0	5.6
50	4.8	6.4	4.5	6.1	4.2	5.8	4.0	5.6	3.7	5.3	3.4	5.0
52	4.3	5.8	4.0	5.6	3.7	5.3	3.5	5.0	3.2	4.7	2.9	4.5
54	3.8	5.3	3.6	5.0	3.3	4.8	3.0	4.5	2.7	4.2	2.5	3.9
56	3.4	4.8	3.2	4.6	2.9	4.3	2.6	4.0	2.3	3.7	2.0	3.5
58	2.9/58.8	4.2/58.8	2.8	4.1	2.5	3.8	2.2	3.6	1.9	3.3	1.7	3.0
60			2.4	3.7	2.1	3.4	1.8	3.2	1.5	2.9	1.3	2.6
Counterweight	52	52+11	52	52+11	52	52+11	52	52+11	52	52+11	52	52+11
Multiply	3	3	3	3	2	2	2	2	2	2	2	2

FJ OPERATING CONDITIONS

Jib length (m)	Jib insert		Boom length (m)	Boom to jib angle
	3 m	6 m		
13	1	–	27~75	15° , 30°
19	1	1	27~69	15° , 30°
25	1	2	33~69	15° , 30°
31	1	3	39~69	15° , 30°

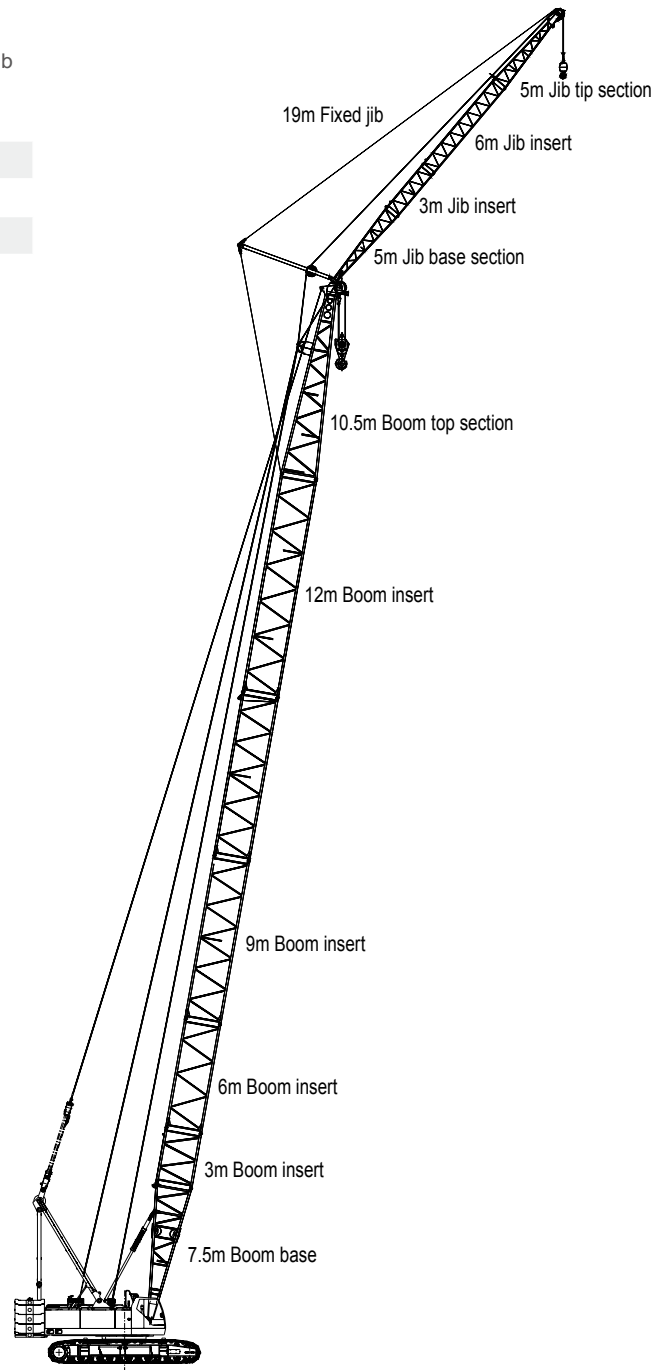

57m boom + 19m Jib

FIXED JIB RANGE DIAGRAM

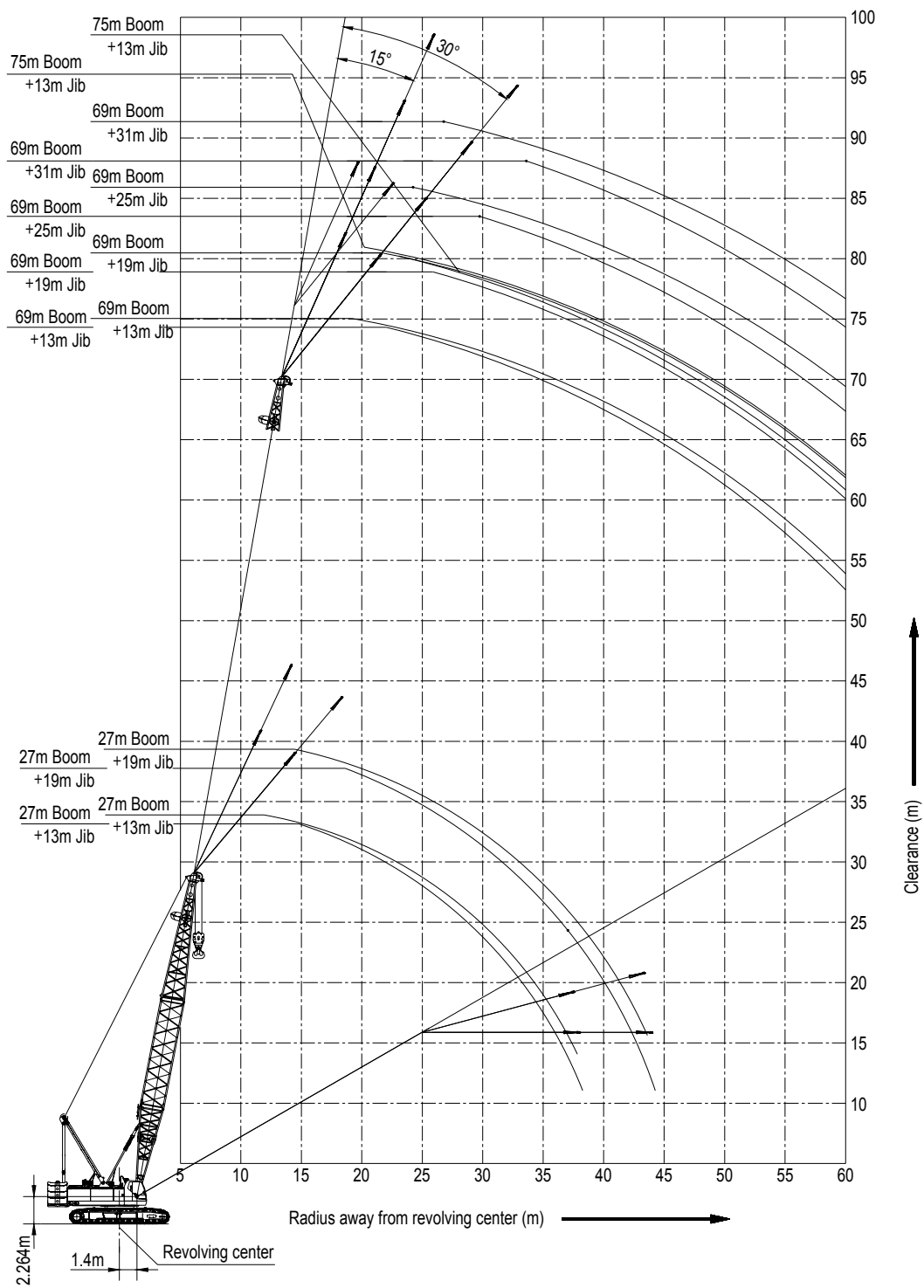

FIXED JIB LOAD CHARTS

Note:

1. Filling part of 25% gray level in bold frame in the table is determined by strength. Italic value filled by 40% gray level refers to the operating conditions with standard and additional counterweights.
2. Rated load in the table is the maximum permissible value under the condition that the non-traveling heavy load is slowly and stably lifted from the solid and flat ground.
3. Rated load shown in the table is calculated based on the 75% of tilting load under wind speed of less than 9.8m/s. Value unit expressed by load is "t". Actual hoisting weight is value by deducting mass of main or auxiliary lifting hook from rated hoisting weight in the table. Weight of lifting hook is shown as follows:
 - 150t hook block -2.8t
 - 100t hook block --1.99t
 - 50t hook block --1.06t
 - 25t hook block -0.79t
 - 13.5t hook block -0.53t
4. All values in load chart are available for 360° rotation.
5. Length of installable boom is from 18m to 81m.
6. It is selected operating condition with additional counterweight (52t+11t) and it does not belong to standard operating conditions. Length of boom with additional counterweight allowed is from 45m to 81m.

FIXED JIB LOAD CHARTS

Fixed jib load charts 1/9

Unit: (t)

Boom length (m)		27				30				33			
Jib length (m)	13		19		13		19		13		19		
Jib angle	15°	30°	15°	30°	15°	30°	15°	30°	15°	30°	15°	30°	
Radius (m)													
12	13.0/12.3				13.0/12.9				13.0/13.4				
14	13.0	9.0/15.1	8.0/14.9		13.0	9.0/15.7	8.0/15.5		13.0				
16	13.0	9.0	8.0		13.0	9.0	8.0		13.0	9.0/16.3	8.0/16.1		
18	13.0	9.0	8.0	6.0/19.1	13.0	9.0	8.0	6.0/19.6	13.0	9.0	8.0		
20	13.0	9.0	8.0	6.0	13.0	9.0	8.0	6.0	13.0	9.0	8.0	6.0/20.2	
22	13.0/23.2	9.0	8.0	6.0	13.0	9.0	8.0	6.0	13.0	9.0	8.0	6.0	
24	12.7	9.0	8.0	6.0	13.0/24.8	9.0	8.0	6.0	13.0	9.0	8.0	6.0	
26	12.3/24.9	9.0/24.9	8.0/24.9	6.0/24.9	12.5	9.0	8.0	6.0	13.0	9.0	8.0	6.0	
28					11.9/27.5	9.0/27.5	8.0/27.5	6.0/27.5	12.3	9.0	8.0	6.0	
30									11.6/30.1	9.0/30.1	8.0/30.1	6.0/30.1	
32													
34													
Counterweight	52	52	52	52	52	52	52	52	52	52	52	52	
Boom length (m)		33				36				39			
Jib length (m)	25		13		19		25		13		19		
Jib angle	15°	30°	15°	30°	15°	30°	15°	30°	15°	30°	15°	30°	
Radius (m)													
14			13.0/14.1						13.0/14.6				
16			13.0	9.0/16.9	8.0/16.7				13.0	9.0/17.4	8.0/17.2		
18	5.0/18.7		13.0	9.0	8.0		5.0/19.3		13.0	9.0	8.0		
20	5.0		13.0	9.0	8.0	6.0/20.8	5.0		13.0	9.0	8.0	6.0/21.4	
22	5.0		13.0	9.0	8.0	6.0	5.0		13.0	9.0	8.0	6.0	
24	5.0	4.6/24.2	13.0	9.0	8.0	6.0	5.0	4.6/24.7	13.0	9.0	8.0	6.0	
26	5.0	4.6	13.0/27.6	9.0	8.0	6.0	5.0	4.6	13.0	9.0	8.0	6.0	
28	5.0	4.6	12.8	9.0	8.0	6.0	5.0	4.6	13.0/29.0	9.0	8.0	6.0	
30	5.0/30.1	4.6/30.1	12.2	9.0	8.0	6.0	5.0	4.6	12.7	9.0	8.0	6.0	
32			11.6	9.0	8.0	6.0	5.0	4.6	12.1	9.0	8.0	6.0	
34			11.4/32.7	9.0/32.7	8.0/32.7	6.0/32.7	5.0/32.7	4.6/32.7	11.5	9.0	8.0	6.0	
36									10.9/35.3	9.0/35.3	8.0/35.3	6.0/35.3	
Counterweight	52	52	52	52	52	52	52	52	52	52	52	52	

FIXED JIB LOAD CHARTS

Fixed jib load charts 2/9

Unit: (t)

Boom length (m) 39																	
Jib length (m)	25		31														
Jib angle	15°	30°	15°	30°													
Radius (m)																	
14																	
16																	
18	5.0/19.9																
20	5.0																
22	5.0		3.0/22.5														
24	5.0	4.6/25.3	3.0														
26	5.0	4.6	3.0														
28	5.0	4.6	3.0	2.6/29.2													
30	5.0	4.6	3.0	2.6													
32	5.0	4.6	3.0	2.6													
34	5.0	4.6	3.0	2.6													
36	5.0/35.3	4.6/35.3	3.0/35.3	2.6/35.3													
Counterweight	52	52	52	52													
Boom length (m) 42																	
Jib length (m)	13		19		25		31				13						
Jib angle	15°	30°	15°	30°	15°	30°	15°	30°			15°	30°					
Radius (m)																	
16	13.0/15.2		8.0/17.8											13.0	13.0		
18	13.0		8.0											13.0	13.0	9.0/18.6	9.0/18.6
20	13.0	9.0	8.0	6.0/21.9	5.0/20.4						13.0	13.0	9.0	9.0			
22	13.0	9.0	8.0	6.0	5.0	3.0/23.1							13.0	13.0	9.0	9.0	
24	13.0	9.0	8.0	6.0	5.0	4.6/25.9	3.0						13.0	13.0	9.0	9.0	
26	13.0	9.0	8.0	6.0	5.0	4.6	3.0						13.0	13.0	9.0	9.0	
28	13.0	9.0	8.0	6.0	5.0	4.6	3.0	2.6/29.8					13.0	13.0	9.0	9.0	
30	13.0	9.0	8.0	6.0	5.0	4.6	3.0	2.6	13.0/30.7	13.0				9.0	9.0		
32	13.0	9.0	8.0	6.0	5.0	4.6	3.0	2.6	12.2	13.0				9.0	9.0		
34	12.3	9.0	8.0	6.0	5.0	4.6	3.0	2.6	11.2	13.0/33.5			9.0	9.0			
36	11.3	9.0	8.0	6.0	5.0	4.6	3.0	2.5	10.3	11.8			9.0	9.0			
38	10.4	9.0	8.0/37.9	6.0/37.9	5.0/37.9	4.6/37.9	2.9/37.9	2.4/37.9	9.5	10.9			9.0/39.5	9.0			
40	9.0/37.9	9.0/37.9												8.8	10.1	8.8	9.0
42											8.6/40.5	9.9/40.5	8.6/40.5	9.0/40.5			
Counterweight	52	52	52	52	52	52	52	52	52	52	52+11	52	52+11				

FIXED JIB LOAD CHARTS

Fixed jib load charts 3/9

Unit: (t)

Boom length (m)		45											
Jib length (m)		19				25				31			
Jib angle		15°		30°		15°		30°		15°		30°	
Radius (m)													
18	8.0/18.4	8.0/18.4											
20	8.0	8.0			5.0/21.0	5.0/21.0							
22	8.0	8.0	6.0/22.5	6.0/22.5	5.0	5.0				3.0/23.6	3.0/23.6		
24	8.0	8.0	6.0	6.0	5.0	5.0				3.0	3.0		
26	8.0	8.0	6.0	6.0	5.0	5.0	4.6/26.4	4.6/26.4		3.0	3.0		
28	8.0	8.0	6.0	6.0	5.0	5.0	4.6	4.6		3.0	3.0		
30	8.0	8.0	6.0	6.0	5.0	5.0	4.6	4.6		3.0	3.0	2.4/30.4	2.4/30.4
32	8.0	8.0	6.0	6.0	5.0	5.0	4.6	4.6		3.0	3.0	2.4	2.4
34	8.0	8.0	6.0	6.0	5.0	5.0	4.6	4.6		3.0	3.0	2.4	2.4
36	8.0	8.0	6.0	6.0	5.0	5.0	4.6	4.6		3.0	3.0	2.4	2.4
38	8.0	8.0	6.0	6.0	5.0	5.0	4.6	4.6		2.9	3.0	2.4	2.4
40	8.0	8.0	6.0	6.0	5.0	5.0	4.6	4.6		2.8	3.0	2.4	2.4
42	8.0/40.5	8.0/40.5	6.0/40.5	6.0/40.5	5.0/40.5	5.0/40.5	4.6/40.5	4.6/40.5		2.7/40.5	3.0/40.5	2.4/40.5	2.4/40.5
Counterweight	52	52+11	52	52+11	52	52+11	52	52+11	52	52+11	52	52+11	52+11
Boom length (m)		48											
Jib length (m)		13				19				25			
Jib angle		15°		30°		15°		30°		15°		30°	
Radius (m)													
16	13.0/16.3	13.0/16.3											
18	13.0	13.0	9.0/19.1	9.0/19.1	8.0/18.9	8.0/18.9							
20	13.0	13.0	9.0	9.0	8.0	8.0				5.0/21.6	5.0/21.6		
22	13.0	13.0	9.0	9.0	8.0	8.0	6.0/23.1	6.0/23.1		5.0	5.0		
24	13.0	13.0	9.0	9.0	8.0	8.0	6.0	6.0		5.0	5.0		
26	13.0	13.0	9.0	9.0	8.0	8.0	6.0	6.0		5.0	5.0	4.6/27.0	4.6/27.0
28	13.0	13.0	9.0	9.0	8.0	8.0	6.0	6.0		5.0	5.0	4.6	4.6
30	13.0/30.5	13.0	9.0	9.0	8.0	8.0	6.0	6.0		5.0	5.0	4.6	4.6
32	12.1	13.0	9.0	9.0	8.0	8.0	6.0	6.0		5.0	5.0	4.6	4.6
34	11.0	12.7	9.0	9.0	8.0	8.0	6.0	6.0		5.0	5.0	4.6	4.6
36	10.1	11.6	9.0	9.0	8.0	8.0	6.0	6.0		5.0	5.0	4.6	4.6
38	9.3	10.7	9.0/38.8	9.0	8.0	8.0	6.0	6.0		5.0	5.0	4.6	4.6
40	8.6	9.9	8.6	9.0	8.0	8.0	6.0	6.0		5.0	5.0	4.6	4.6
42	8.0	9.2	8.0	9.0	8.0	8.0	6.0	6.0		5.0	5.0	4.6	4.6
44	7.7/43.1	8.9/43.1	7.7/43.1	8.5/43.1	7.7/43.1	8.0/43.1	6.0/43.1	6.0/43.1		5.0/43.1	5.0/43.1	4.6/43.1	4.6/43.1
Counterweight	52	52+11	52	52+11	52	52+11	52	52+11	52	52+11	52	52+11	52+11

FIXED JIB LOAD CHARTS

Fixed jib load charts 4/9

Unit: (t)

Boom length (m)		48											
Jib length (m)		31											
Jib angle		15°						30°					
Radius (m)													
24	3.0/24.2	3.0/24.2											
26	3.0	3.0											
28	3.0	3.0											
30	3.0	3.0	2.6/31.0	2.6/31.0									
32	3.0	3.0	2.6	2.6									
34	3.0	3.0	2.6	2.6									
36	3.0	3.0	2.6	2.6									
38	3.0	3.0	2.6	2.6									
40	2.9	3.0	2.5	2.6									
42	2.8	3.0	2.5	2.6									
44	2.75/43.1	3.0/43.1	2.4/43.1	2.6/43.1									
Counterweight	52	52+11	52	52+11									

Boom length (m)		51											
Jib length (m)		13				19				25			
Jib angle		15°		30°		15°		30°		15°		30°	
Radius (m)													
16	13.0/16.9	13.0/16.9											
18	13.0	13.0	9.0/19.7	9.0/19.7	8.0/19.5	8.0/19.5							
20	13.0	13.0	9.0	9.0	8.0	8.0							
22	13.0	13.0	9.0	9.0	8.0	8.0	6.0/23.6	6.0/23.6	5.0/22.1	5.0/22.1			
24	13.0	13.0	9.0	9.0	8.0	8.0	6.0	6.0	5.0	5.0			
26	13.0	13.0	9.0	9.0	8.0	8.0	6.0	6.0	5.0	5.0	4.6/27.6	4.6/27.6	
28	13.0	13.0	9.0	9.0	8.0	8.0	6.0	6.0	5.0	5.0	4.6	4.6	
30	13.0/30.1	13.0	9.0	9.0	8.0	8.0	6.0	6.0	5.0	5.0	4.6	4.6	
32	11.9	13.0	9.0	9.0	8.0	8.0	6.0	6.0	5.0	5.0	4.6	4.6	
34	10.9	12.5	9.0	9.0	8.0	8.0	6.0	6.0	5.0	5.0	4.6	4.6	
36	10.0	11.5	9.0	9.0	8.0	8.0	6.0	6.0	5.0	5.0	4.6	4.6	
38	9.2	10.6	9.0/38.5	9.0	8.0	8.0	6.0	6.0	5.0	5.0	4.6	4.6	
40	8.5	9.8	8.5	9.0	8.0/41.3	8.0	6.0	6.0	5.0	5.0	4.6	4.6	
42	7.8	9.0	7.8	9.0	7.8	8.0	6.0	6.0	5.0	5.0	4.6	4.6	
44	7.3	8.4	7.3	8.4	7.3	8.0	6.0	6.0	5.0	5.0	4.6	4.6	
46	6.8/45.7	7.8/45.7	6.8/45.7	7.8/45.7	6.8/45.7	7.8/45.7	6.0/45.7	6.0/45.7	5.0/45.7	5.0/45.7	4.6/45.7	4.6/45.7	
Counterweight	52	52+11	52	52+11	52	52+11	52	52+11	52	52+11	52	52+11	52

FIXED JIB LOAD CHARTS

Fixed jib load charts 5/9

Unit: (t)

Boom length (m)		51				54				57			
Jib length (m)		31				13				19			
Jib angle		15°		30°		15°		30°		15°		30°	
Radius (m)		15°		30°		15°		30°		15°		30°	
16						13.0	13.0						
18						13.0	13.0						
20						13.0	13.0	9.0/20.3	9.0/20.3	8.0/20.1	8.0/20.1		
22	3.0/28.4	3.0/28.4				13.0	13.0	9.0	9.0	8.0	8.0		
24	3.0	3.0				13.0	13.0	9.0	9.0	8.0	8.0	6.0/24.2	6.0/24.2
26	3.0	3.0				13.0	13.0	9.0	9.0	8.0	8.0	6.0	6.0
28	3.0	3.0	2.6/31.5	2.6/31.5		13.0	13.0	9.0	9.0	8.0	8.0	6.0	6.0
30	3.0	3.0	2.6	2.6		13.0	13.0	9.0	9.0	8.0	8.0	6.0	6.0
32	3.0	3.0	2.6	2.6		11.8	13.0	9.0	9.0	8.0	8.0	6.0	6.0
34	3.0	3.0	2.6	2.6		10.7	12.3	9.0	9.0	8.0	8.0	6.0	6.0
36	3.0	3.0	2.6	2.6		9.8	11.3	9.0	9.0	8.0	8.0	6.0	6.0
38	3.0	3.0	2.5	2.6		9.0	10.4	9.0	9.0	8.0	8.0	6.0	6.0
40	2.9	3.0	2.5	2.6		8.3	9.5	8.3	9.0	8.0/40.9	8.0	6.0	6.0
42	2.9	3.0	2.4	2.6		7.6	8.7	7.6	8.7	7.6	8.0	6.0	6.0
44	2.8/45.7	3.0/45.7	2.35/45.7	2.5/45.7		7.1	8.2	7.1	8.2	7.1	8.0	6.0	6.0
46						6.5	7.5	6.5	7.5	6.5	7.5	6.0	6.0
48						6.1	7.0	6.1	7.0	6.1	7.0	6.0	6.0
50						6.0/48.3	6.9/48.3	6.0/48.3	6.9/48.3	6.0/48.3	6.9/48.3	6.0/48.3	6.0/48.3
Counterweight	52	52+11	52	52+11	52	52+11	52	52+11	52	52+11	52	52+11	52+11
Boom length (m)		54				57				57			
Jib length (m)		25				31				13			
Jib angle		15°		30°		15°		30°		15°		30°	
Radius (m)		15°		30°		15°		30°		15°		30°	
16										13.0	13.0		
18										13.0	13.0	9.0/20.9	9.0/20.9
20										13.0	13.0	9.0	9.0
22	5.0/22.7	5.0/22.7								13.0	13.0	9.0	9.0
24	5.0	5.0				3.0/25.3	3.0/25.3			13.0	13.0	9.0	9.0
26	5.0	5.0				3.0	3.0			13.0/29.8	13.0	9.0	9.0
28	5.0	5.0	4.6/28.2	4.6/28.2		3.0	3.0			12.8	13.0	9.0	9.0
30	5.0	5.0	4.6	4.6		3.0	3.0			11.6	13.0	9.0	9.0
32	5.0	5.0	4.6	4.6		3.0	3.0	2.6/32.1	2.6/32.1	10.5	12.1	9.0	9.0
34	5.0	5.0	4.6	4.6		3.0	3.0	2.6	2.6	9.6	11.0	9.0/37.4	9.0
36	5.0	5.0	4.6	4.6		3.0	3.0	2.6	2.6	8.8	10.1	8.8	9.0
38	5.0	5.0	4.6	4.6		3.0	3.0	2.6	2.6	8.1	9.3	8.1	9.0
40	5.0	5.0	4.6	4.6		3.0	3.0	2.6	2.6	7.4	8.5	7.4	8.5
42	5.0	5.0	4.6	4.6		2.9	3.0	2.5	2.6	6.9	7.9	6.9	7.9
44	5.0	5.0	4.6	4.6		2.9	3.0	2.5	2.6	6.3	7.2	6.3	7.2
46	5.0	5.0	4.6	4.6		2.8	3.0	2.4	2.6	5.9	6.8	5.9	6.8
48	5.0	5.0	4.6	4.6		2.8	3.0	2.4	2.6	5.5	6.3	5.5	6.3
50	5.0/48.3	5.0/48.3	4.6/48.3	4.6/48.3		2.7/48.3	3.0/48.3	2.3/48.3	2.6/48.3	5.3/50.9	6.1/50.9	5.3/50.9	6.1/50.9
Counterweight	52	52+11	52	52+11	52	52+11	52	52+11	52	52+11	52	52+11	52+11

FIXED JIB LOAD CHARTS

Fixed jib load charts 6/9

Unit: (t)

Boom length (m)		57											
Jib length (m)		19				25				31			
Jib angle		15°		30°		15°		30°		15°		30°	
Radius (m)													
18	8.0/20.7	8.0/20.7											
20	8.0	8.0			5.0/23.3	5.0/23.3							
22	8.0	8.0	6.0/24.8	6.0/24.8	5.0	5.0				3.0/25.5	3.0/25.5		
24	8.0	8.0	6.0	6.0	5.0	5.0				3.0	3.0		
26	8.0	8.0	6.0	6.0	5.0	5.0	4.6/28.7	4.6/28.7		3.0	3.0		
28	8.0	8.0	6.0	6.0	5.0	5.0	4.6	4.6		3.0	3.0		
30	8.0	8.0	6.0	6.0	5.0	5.0	4.6	4.6		3.0	3.0	2.6/32.7	2.6/32.7
32	8.0	8.0	6.0	6.0	5.0	5.0	4.6	4.6		3.0	3.0	2.6	2.6
34	8.0	8.0	6.0	6.0	5.0	5.0	4.6	4.6		3.0	3.0	2.6	2.6
36	8.0	8.0	6.0	6.0	5.0	5.0	4.6	4.6		3.0	3.0	2.6	2.6
38	8.0/40.1	8.0	6.0	6.0	5.0	5.0	4.6	4.6		3.0	3.0	2.6	2.6
40	7.4	8.0	6.0	6.0	5.0	5.0	4.6	4.6		3.0	3.0	2.6	2.6
42	6.9	7.9	6.0	6.0	5.0	5.0	4.6	4.6		2.9	3.0	2.5	2.6
44	6.3	7.2	6.0/47.5	6.0	5.0	5.0	4.6	4.6		2.9	3.0	2.5	2.6
46	5.9	6.8	5.9	6.0	5.0	5.0	4.6	4.6		2.8	3.0	2.4	2.6
48	5.5	6.3	5.5	6.0	5.0	5.0	4.6	4.6		2.8	3.0	2.4	2.6
50	5.3/50.9	6.1/50.9	5.3/50.9	6.0/50.9	5.0/50.9	5.0/50.9	4.6/50.9	4.6/50.9	2.7/50.9	3.0/50.9	3.0/50.9	2.3/50.9	2.6/50.9
Counterweight	52	52+11	52	52+11	52	52+11	52	52+11	52	52+11	52	52+11	52+11
Boom length (m)		60											
Jib length (m)		13				19				25			
Jib angle		15°		30°		15°		30°		15°		30°	
Radius (m)													
18	13.0/18.6	13.0/18.6											
20	13.0	13.0	9.0/21.4	9.0/21.4	8.0/21.2	8.0/21.2							
22	13.0	13.0	9.0	9.0	8.0	8.0				5.0/23.9	5.0/23.9		
24	13.0	13.0	9.0	9.0	8.0	8.0	6.0/25.4	6.0/25.4		5.0	5.0		
26	13.0	13.0	9.0	9.0	8.0	8.0	6.0	6.0		5.0	5.0		
28	13.0	13.0	9.0	9.0	8.0	8.0	6.0	6.0		5.0	5.0	4.6/29.3	4.6/29.3
30	13.0	13.0	9.0	9.0	8.0	8.0	6.0	6.0		5.0	5.0	4.6	4.6
32	11.8	13.0	9.0	9.0	8.0	8.0	6.0	6.0		5.0	5.0	4.6	4.6
34	10.7	12.3	9.0	9.0	8.0	8.0	6.0	6.0		5.0	5.0	4.6	4.6
36	9.7	11.2	9.0/36.7	9.0	8.0	8.0	6.0	6.0		5.0	5.0	4.6	4.6
38	8.9	10.2	8.9	9.0	8.0	8.0	6.0	6.0		5.0	5.0	4.6	4.6
40	8.2	9.4	8.2	9.0	8.0/40.7	8.0	6.0	6.0		5.0	5.0	4.6	4.6
42	7.5	8.6	7.5	8.6	7.5	8.0	6.0	6.0		5.0	5.0	4.6	4.6
44	6.9	7.9	6.9	7.9	6.9	7.9	6.0	6.0		5.0	5.0	4.6	4.6
46	6.3	7.2	6.3	7.2	6.3	7.2	6.0/47.2	6.0		5.0	5.0	4.6	4.6
48	5.9	6.8	5.9	6.8	5.9	6.8	5.9	6.0		5.0	5.0	4.6	4.6
50	5.4	6.2	5.4	6.2	5.4	6.2	5.4	6.0		5.0	5.0	4.6	4.6
52	5.0	5.8	5.0	5.8	5.0	5.8	5.0	5.8		5.0	5.0	4.6	4.6
54	4.7/53.5	5.4/53.5	4.7/53.5	5.4/53.5	4.7/53.5	5.4/53.5	4.7/53.5	5.4/53.5	4.7/53.5	5.0/53.5	5.0/53.5	4.6/53.5	4.6/53.5
Counterweight	52	52+11	52	52+11	52	52+11	52	52+11	52	52+11	52	52+11	52+11

FIXED JIB LOAD CHARTS

Fixed jib load charts 7/9

Unit: (t)

Boom length (m)	60				63				66			
Jib length (m)	31				13				19			
Jib angle	15°		30°		15°		30°		15°		30°	
Radius (m)												
18					13.0/19.2	13.0/19.2						
20					13.0	13.0			8.0/21.8	8.0/21.8		
22					13.0	13.0	9.0	9.0	8.0	8.0		
24					13.0	13.0	9.0	9.0	8.0	8.0	6.0/25.9	6.0/25.9
26	3.0/26.5	3.0/26.5			13.0	13.0	9.0	9.0	8.0	8.0	6.0	6.0
28	3.0	3.0			13.0/29.8	13.0	9.0	9.0	8.0	8.0	6.0	6.0
30	3.0	3.0			11.8	13.0	9.0	9.0	8.0	8.0	6.0	6.0
32	3.0	3.0	2.6/33.2	2.6/33.2	11.6	13.0	9.0	9.0	8.0	8.0	6.0	6.0
34	3.0	3.0	2.6	2.6	10.5	12.1	9.0	9.0	8.0	8.0	6.0	6.0
36	3.0	3.0	2.6	2.6	9.5	10.9	9.0/37.3	9.0	8.0	8.0	6.0	6.0
38	3.0	3.0	2.6	2.6	8.7	10.0	8.7	9.0	8.0	8.0	6.0	6.0
40	3.0	3.0	2.6	2.6	8.0	10.0	8.0	9.0	8.0	8.0	6.0	6.0
42	3.0	3.0	2.6	2.6	7.3	8.4	7.3	8.4	7.3	8.0	6.0	6.0
44	3.0	3.0	2.5	2.6	6.7	7.7	6.7	7.7	6.7	7.7	6.0	6.0
46	2.9	3.0	2.5	2.6	6.1	7.0	6.1	7.0	6.1	7.0	6.0/46.6	6.0
48	2.9	3.0	2.4	2.6	5.7	6.6	5.7	6.6	5.7	6.6	5.7	6.0
50	2.8	3.0	2.4	2.6	5.2	6.0	5.2	6.0	5.2	6.0	5.2	6.0
52	2.8	3.0	2.3	2.6	4.7	5.4	4.7	5.4	4.7	5.4	4.7	5.4
54	52.5	52.5	52.5	52.5	4.3	4.9	4.3	4.9	4.3	4.9	4.3	4.9
56					3.9/56.1	4.5/56.1	3.9/56.1	4.5/56.1	3.9/56.1	4.5/56.1	3.9/56.1	4.5/56.1
Counterweight	52	52+11	52	52+11	52	52+11	52	52+11	52	52+11	52	52+11
Boom length (m)					63				66			
Jib length (m)	25				31				13			
Jib angle	15°		30°		15°		30°		15°		30°	
Radius (m)												
18									13.0/19.2	13.0/19.2		
20									13.0	13.0		
22									13.0	13.0	9.0/22.6	9.0/22.6
24	5.0/24.4	5.0/24.4							13.0	13.0	9.0	9.0
26	5.0	5.0			3.0/27.1	3.0/27.1			13.0	13.0	9.0	9.0
28	5.0	5.0	4.6/29.9	4.6/29.9	3.0	3.0			13.0/29.5	13.0	9.0	9.0
30	5.0	5.0	4.6	4.6	3.0	3.0			11.7	13.0	9.0	9.0
32	5.0	5.0	4.6	4.6	3.0	3.0	2.6/33.8	2.6/33.8	11.4	13.0	9.0	9.0
34	5.0	5.0	4.6	4.6	3.0	3.0	2.6	2.6	10.4	12.0	9.0	9.0
36	5.0	5.0	4.6	4.6	3.0	3.0	2.6	2.6	9.4	10.8	9.0/36.8	9.0
38	5.0	5.0	4.6	4.6	3.0	3.0	2.6	2.6	8.6	9.9	8.6	9.0
40	5.0	5.0	4.6	4.6	3.0	3.0	2.6	2.6	7.8	9.0	7.8	9.0
42	5.0	5.0	4.6	4.6	3.0	3.0	2.6	2.6	7.1	8.2	7.1	8.2
44	5.0	5.0	4.6	4.6	3.0	3.0	2.5	2.6	6.5	7.5	6.5	7.5
46	5.0	5.0	4.6	4.6	3.0	3.0	2.5	2.6	6.0	6.9	6.0	6.9
48	5.0	5.0	4.6	4.6	2.9	3.0	2.4	2.6	5.5	6.3	5.5	6.3
50	5.0/50.5	5.0	4.6	4.6	2.9	3.0	2.4	2.6	5.0	5.8	5.0	5.8
52	4.7	5.0	4.6/52.4	4.6	2.8	3.0	2.3	2.6	4.5	5.2	4.5	5.2
54	4.3	4.9	4.3	4.6	2.8	3.0	2.3	2.6	4.1	4.7	4.1	4.7
56	3.9/56.1	4.5/56.1	3.9/56.1	4.5/56.1	2.7/56.1	3.0/56.1	2.2/56.1	2.5/56.1	3.7	4.3	3.7	4.3
58									3.3	3.8	3.3	3.8
60									3.2/58.7	3.7/58.7	3.2/58.7	3.7/58.7
Counterweight	52	52+11	52	52+11	52	52+11	52	52+11	52	52+11	52	52+11

FIXED JIB LOAD CHARTS

Fixed jib load charts 8/9

Unit: (t)

Boom length (m)		66												
Jib length (m)		19				25				31				
Jib angle		15°		30°		15°		30°		15°		30°		
Radius (m)														
22	8.0/22.4	8.0/22.4												
24	8.0	8.0			5.0/25.0	5.0/25.0								
26	8.0	8.0	6.0/26.5	6.0/26.5	5.0	5.0				3.0/27.6	3.0/27.6			
28	8.0	8.0	6.0	6.0	5.0	5.0				3.0	3.0			
30	8.0	8.0	6.0	6.0	5.0	5.0	4.6/30.4	4.6/30.4		3.0	3.0			
32	8.0	8.0	6.0	6.0	5.0	5.0	4.6	4.6		3.0	3.0			
34	8.0	8.0	6.0	6.0	5.0	5.0	4.6	4.6		3.0	3.0	2.6/34.4	2.6/34.4	
36	8.0	8.0	6.0	6.0	5.0	5.0	4.6	4.6		3.0	3.0	2.6	2.6	
38	8.0/39.4	8.0	6.0	6.0	5.0	5.0	4.6	4.6		3.0	3.0	2.6	2.6	
40	7.8	8.0	6.0	6.0	5.0	5.0	4.6	4.6		3.0	3.0	2.6	2.6	
42	7.1	8.0	6.0	6.0	5.0	5.0	4.6	4.6		3.0	3.0	2.6	2.6	
44	6.5	7.5	6.0	6.0	5.0	5.0	4.6	4.6		3.0	3.0	2.5	2.6	
46	6.0	6.9	6.0	6.0	5.0	5.0	4.6	4.6		3.0	3.0	2.5	2.6	
48	5.5	6.3	5.5	6.0	5.0	5.0	4.6	4.6		2.9	3.0	2.4	2.6	
50	5.0	5.8	5.0	5.8	5.0	5.0	4.6/51.6	4.6		2.9	3.0	2.4	2.6	
52	4.5	5.2	4.5	5.2	4.5	5.0	4.5	4.6		2.8	3.0	2.3	2.6	
54	4.1	4.7	4.1	4.7	4.1	4.7	4.1	4.6		2.8	3.0	2.3	2.6	
56	3.7	4.3	3.7	4.3	3.7	4.3	3.7	4.3		2.7	3.0	2.2	2.5	
58	3.3	3.8	3.3	3.8	3.3	3.8	3.3	3.8		2.7	3.0	2.2	2.5	
60	3.2/58.7	3.7/58.7	3.2/58.7	3.7/58.7	3.2/58.7	3.7/58.7	3.2/58.7	3.7/58.7		2.6/58.7	3.0/58.7	2.1/58.7	2.4/58.7	
Counterweight	52	52+11	52	52+11	52	52+11	52	52+11	52	52+11	52	52+11	52	52+11
Boom length (m)		69												
Jib length (m)		13				19				25				
Jib angle		15°		30°		15°		30°		15°		30°		
Radius (m)														
20	13.0/20.3	13.0/20.3												
22	13.0	13.0	9.0/23.1	9.0/23.1	8.0/22.9	8.0/22.9								
24	13.0	13.0	9.0	9.0	8.0	8.0				5.0/25.6	5.0/25.6			
26	13.0	13.0	9.0	9.0	8.0	8.0	6.0/27.1	6.0/27.1		5.0	5.0			
28	13.0/29.3	13.0	9.0	9.0	8.0	8.0	6.0	6.0		5.0	5.0			
30	12.6	13.0	9.0	9.0	8.0	8.0	6.0	6.0		5.0	5.0	4.6/31.0	4.6/31.0	
32	11.4	13.0	9.0	9.0	8.0	8.0	6.0	6.0		5.0	5.0	4.6	4.6	
34	10.3	11.8	9.0	9.0	8.0	8.0	6.0	6.0		5.0	5.0	4.6	4.6	
36	9.3	10.7	9.0/36.5	9.0	8.0	8.0	6.0	6.0		5.0	5.0	4.6	4.6	
38	8.5	9.8	8.5	9.0	8.0/39.4	8.0	6.0	6.0		5.0	5.0	4.6	4.6	
40	7.7	8.9	7.7	8.9	7.7	8.0	6.0	6.0		5.0	5.0	4.6	4.6	
42	7.1	8.2	7.1	8.2	7.1	8.0	6.0	6.0		5.0	5.0	4.6	4.6	
44	6.5	7.5	6.5	7.5	6.5	7.5	6.0/45.6	6.0		5.0	5.0	4.6	4.6	
46	5.9	6.8	5.9	6.8	5.9	6.8	5.9	6.0		5.0	5.0	4.6	4.6	
48	5.4	6.2	5.4	6.2	5.4	6.2	5.4	6.0	5.0/49.6	5.0	5.0	4.6	4.6	
50	4.9	5.6	4.9	5.6	4.9	5.6	4.9	5.6		4.9	5.0	4.6/51.2	4.6	
52	4.4	5.1	4.4	5.1	4.4	5.1	4.4	5.1		4.4	5.0	4.4	4.6	
54	3.9	4.5	3.9	4.5	3.9	4.5	3.9	4.5		3.9	4.5	3.9	4.5	
56	3.5	4.0	3.5	4.0	3.5	4.0	3.5	4.0		3.5	4.0	3.5	4.0	
58	3.2	3.7	3.2	3.7	3.2	3.7	3.2	3.7		3.2	3.7	3.2	3.7	
60	2.8	3.2	2.8	3.2	2.8	3.2	2.8	3.2		2.8	3.2	2.8	3.2	
Counterweight	52	52+11	52	52+11	52	52+11	52	52+11	52	52+11	52	52+11	52	52+11

FIXED JIB LOAD CHARTS

Fixed jib load charts 9/9

Unit: (t)

Boom length (m)	69				75				
Jib length (m)	31				13				
Jib angle	15°		30°		15°		30°		
Radius (m)									
6									
8									
10									
12									
14									
16									
18									
20					13.0/21.5	13.0/21.5			
22					13.0	13.0			
24					13.0	13.0	9.0/24.3	9.0/24.3	
26					13.0	13.0	9.0	9.0	
28	3.0/28.2	3.0/28.2			13.0/28.8	13.0	9.0	9.0	
30	3.0	3.0			12.2	13.0	9.0	9.0	
32	3.0	3.0			11.0	12.7	9.0	9.0	
34	3.0	3.0	2.6/35.0	2.6/35.0	9.9	11.4	9.0/35.8	9.0	
36	3.0	3.0	2.6	2.6	8.9	10.2	8.9	9.0	
38	3.0	3.0	2.6	2.6	8.1	9.3	8.1	9.0	
40	3.0	3.0	2.6	2.6	7.3	8.4	7.3	8.4	
42	3.0	3.0	2.6	2.6	6.6	7.6	6.6	7.6	
44	3.0	3.0	2.5	2.6	6.0	6.9	6.0	6.9	
46	3.0	3.0	2.5	2.6	5.4	6.2	5.4	6.2	
48	2.9	3.0	2.4	2.6	4.8	5.5	4.8	5.5	
50	2.9	3.0	2.4	2.6	4.3	4.9	4.3	4.9	
52	2.8	3.0	2.3	2.6	3.8	4.4	3.8	4.4	
54	2.8	3.0	2.3	2.6	3.4	3.9	3.4	3.9	
56	2.7	3.0	2.2	2.5	3.0	3.5	3.0	3.5	
58	2.7	3.0	2.2	2.5	2.6	3.0	2.6	3.0	
60	2.6	3.0	2.1	2.4	2.2	2.5	2.2	2.5	
Counterweight	52	52+11	52	52+11	52	52+11	52	52+11	